

A critical comparison of reflectometry methods for location of wiring faults

Cynthia Furse[†]

*University of Utah Department of Electrical and Computer Engineering, 50 S Campus Drive,
Salt Lake City, Utah 84112, USA*

You Chung Chung[‡]

*Information and Communication Engineering Department, Daegu University, Kyurigsari,
Kyungbuk 712-714, Korea*

Chet Lo^{†*} and Praveen Pendayala^{‡†}

*University of Utah Department of Electrical and Computer Engineering, 50 S Campus Drive,
Salt Lake City, Utah 84112, USA*

(Received August 30, 2004, Accepted December 15, 2005)

Abstract. Aging wiring in buildings, aircraft and transportation systems, consumer products, industrial machinery, etc. is among the most significant potential causes of catastrophic failure and maintenance cost in these structures. Smart wire health monitoring can therefore have a substantial impact on the overall health monitoring of the system. Reflectometry is commonly used for locating faults on wire and cables. This paper compares Time domain reflectometry (TDR), frequency domain reflectometry (FDR), mixed signal reflectometry (MSR), sequence time domain reflectometry (STDR), spread spectrum time domain reflectometry (SSTDR) and capacitance sensors in terms of their accuracy, convenience, cost, size, and ease of use. Advantages and limitations of each method are outlined and evaluated for several types of aircraft cables. The results in this paper can be extrapolated to other types of wire and cable systems.

Keywords: electrical wiring; reflectometry; nondestructive evaluation; aircraft maintenance.

1. Introduction

Aging electrical systems are prevalent in today's society. Airline crashes attributed to aging wiring including TWA 800 and Swissair U11 have brought this issue into the public eye (Furse and Haupt 2001). A full scale evaluation of the problem is difficult. Wiring was not normally considered in lifecycle maintenance. Aircraft maintenance codes, for instance, did not (and in many cases still do not)

[†]Associate Professor, Corresponding Author, E-mail: cfurse@ece.utah.edu

[‡]Assistant Professor, E-mail: youchung@daegu.ac.kr

^{††}Research Assistant Professor, E-mail: clo@ece.utah.edu

^{‡‡}Member Technical Staff, E-mail: praveenp_007@hotmail.com

include a separate category for wiring faults. Instead they are lumped under general electrical failure. Over 90% of home fires are attributed to electrical fires, although it is not clear how many are due to installed wiring and how many to faulty plug-in consumer devices. What is clear is that wiring is prevalent throughout our society, that wiring systems age, and that aging wiring sometimes fails with expensive and dangerous results (NASA 2000). After the recent Space Shuttle Discovery disaster, the risk assessment determined that the wiring is more likely to fail than the tiles that did fail (Lloyd 1999a, 199b). Wiring is not merely a benign component of an electrical system. It is a source of potentially catastrophic failure.

In addition to the safety problem, aircraft wiring systems are a maintenance burden. Wiring is pervasive in aircraft (e.g. 11 miles of wiring in an F-18C/D). One estimate is that between 1 million and 2 million man-hours are required at the operational level to troubleshoot and repair wiring system problems in the U.S. Navy alone each year. Highly trained technicians trouble shoot wiring problems using methods that are 40 years old. In fact, advances in avionics systems, such as Built-In-Test (BIT) have hampered or even misled technicians if the fault turns out to be in the system wiring. Replacement of the complete wiring system in a typical aircraft is estimated to cost \$1-7 million, depending on the aircraft (Conley 2003).

Not surprisingly, after the TWA800 and Swissair 111 disasters, numerous federal programs were devoted to developing methods for locating aircraft wiring faults (NSTC 2000). Visual inspection, the most common traditional method, was determined to be insufficient. Time domain reflectometry (TDR), another traditional method for locating faults, was observed to be accurate but difficult to use (Waddoups 2001, Schmidt 2002, Jani 2003). High voltage test systems are able to locate even small faults, however they are very large and expensive and cannot be used on fueled aircraft (Waddoups 2001, Schmidt 2002, Jani 2003). New methods are needed, and development funds have led to the emergence of a number of different techniques. This paper describes wire test methods that are suitable for handheld or in situ test equipment and compares their advantages and disadvantages. The methods compared are the time domain reflectometer (TDR), frequency domain reflectometer (FDR), mixed signal reflectometer (MSR), sequence time domain reflectometer (STDR), spread spectrum time domain reflectometer (SSTDR) and capacitance sensors (Furse, *et al.* 2003, Chung, *et al.* 2005, Tsai, *et al.* 2005, Furse, Smith, Safavi and Lo 2005, Furse, *et al.* 2005, Chung, *et al.* 2005).

2. Reflectometry for wire testing

Reflectometry methods are among the most commonly used methods for testing wires. A high frequency electrical signal is sent down the wire, where it reflects from any impedance discontinuity. The reflection coefficient (Iskander 1992) gives a measure of how much signal is returned and is given by

$$\Gamma = \frac{V_{reflected}}{V_{incident}} = \frac{Z_o - Z_L}{Z_o + Z_L} \quad (1)$$

where Z_o is the characteristic impedance of the transmission line (values for several typical aircraft cables are given in Table 1), and Z_L is the impedance of the discontinuity. For instance, the reflection coefficient for an open circuit ($Z_L = \text{infinity}$) is 1, and the reflection coefficient for a short circuit ($Z_L =$

Table 1 Capacitance and Inductance per unit length, velocity of propagation, and characteristic impedance of aircraft and miscellaneous cables ($c = 3 \times 10^8$ m/s)

Wire Type *F18 wires (Chung, <i>et al.</i> 2005)	Military and commercial part number	C (pF/m)	L (uH/m)	V_p/c	Impedance (ohms)
*AWG22 Twisted shielded quadruple	M27500-22SC4S23	106.5	0.517	0.69	54
*AWG 24 Twisted shielded triple	M27500-24SC3S23	100.5	0.55	0.66	52
*AWG 24 Twisted pair shielded	M27500-2408T23	102.4	0.544	0.67	55
*AWG 24 Twisted pair shielded	M27500-24SE2S23	84.7	0.614	0.66	60
*AWG 24 twisted pair	M27500-24SC2U00	47.28	0.587	0.71	120
AWG 20 parallel pair speaker wire	20 gauge	49.27	0.785	0.56	100
Coax (Fig. 9)	C4931-22L	339	0.161	0.57	20
AWG 26 twisted pair (Fig. 9)	C4932-26L2	49.61	0.659	0.64	105
AWG 11 Thick twisted triple (Fig 9)	M81381-11-12	90.29	0.467	0.66	55
AWG 11 thick single pair in a bundle (Fig. 9)	M81381-11-12 (C4932-12N3)	49.34	0.651	0.73	100
AWG 20 single pair in a bundle (Fig. 9)	M81381/7-20-2 (C4928-20)	31.76	0.976	0.74	150
AWG 22 single pair in a bundle like (Fig. 9)	M22759/16-22-90	35.15	0.924	0.71	120~150
AWG 22 single pair in a big bundle like (Fig. 2)	M22759-43-22-9	23.36	1.08	0.71	120~160

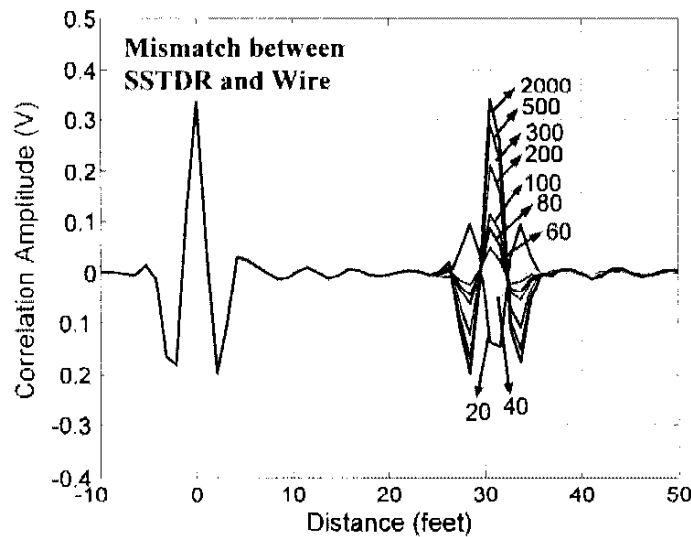

Fig. 1 Spread spectrum time domain reflectometry (SSTDR) responses for different load impedances (given in ohms for a 50Ω wire). The correlation amplitude is proportion to reflection coefficient. Other reflectometry methods will have the same relative peak magnitudes, but different shapes of the pulses

0) is -1. A junction of two branched wires ($Z_L = Z_o / 2$) has a reflection coefficient of -1/3. The time or phase delay between the incident and reflected signals tells the distance to the fault, and the observed magnitude of the reflection coefficient tells what the impedance of the discontinuity is. Hard faults (open and short) are observable by reflectometry, but soft faults (damaged insulation, etc.) are generally not. Fig. 1 shows the measured spread spectrum reflectometry (SSTDR) response for load impedances

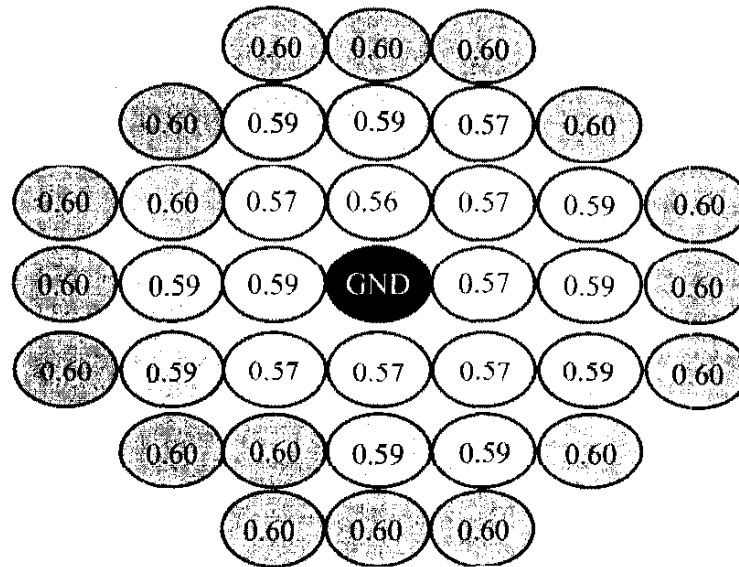

Fig. 2 Distribution of velocity of propagation for a wire bundle. The bundle consists of 36 wires, tied about every foot. Each wire is 20 gauge BMS13-48T10C0 1G020. Value is given relative to velocity of light

ranging from 20 to 2000 ohms for RG58 coax with characteristic impedance 50 ohms. (Other reflectometry methods will have the same relative peak heights, but different shapes.) The height of the peak relative to the maximum peak height gives the reflection coefficient. Impedance discontinuities that are greater than 10 ohms different than the characteristic impedance (reflection coefficients greater than 20%) are relatively easy to identify and locate. Impedance differences below 10 ohms become progressively more difficult to identify, as their response is much smaller, and eventually the peaks from the reflection are smaller than the measurement error.

The delay between the incident and reflected voltages shows up in the location of reflectometry peaks. In Fig. 1, for instance, two peaks are observed. The peak at 0 feet is from the reflection from the mismatch between the wire and test circuitry. The peak at 30 feet is from the load at the end of the wire. In reality, the raw data is actually given as a time delay rather than distance. The distance L is the velocity of propagation divided by the time delay. The velocity of propagation in typical aircraft cables ranges from 0.5 to 0.8 depending on the type of cable (Furse, *et al.* 2003, White 2004). It is therefore very important to know the type of wire being tested. The velocity is dependent on the size and shape of the conductors, and therefore also depends on the distance between conductors. Many aircraft wires are bound together in bundles, often with several hundred wires in a bundle. The location of a specific wire within the bundle is not precisely controlled. Wires may meander through the bundle, sometimes near the center, other times near the surface. This was found to change the velocity of propagation by as much as 3% in a bundle of 36 wires (each is 20 gauge single wire, BMS13-48T10C0 1G020) as shown spatially distributed throughout the bundle in Fig. 2. Wires near the outside tend to have the fastest velocity of propagation, because they have, on average, the largest air volume around them. This variation is unavoidable and unpredictable, so the minimum error that can be expected in any reflectometry measurement of bundled wires of this type is 3%. Similar errors are observed if the wire is moved around between tests, even if it is closely paired with another wire (such as twisted pair or twin

lead wire like lamp cord) (Pendayala 2004). This gives perspective to the errors that will be reported for each reflectometry method described in this paper.

There are several sources of error in reflectometry measurements. The inability to see small reflections and errors in the velocity of propagation are two such errors. Other errors are hardware error (classical measurement error, where some variation in measurements is seen, even without making any changes to the wire under test, its connection, etc.). For the reflectometry methods described below, this is generally less than 1%. Another error is connection error. Since the reflectometer must be connected to a wide variety of cables, it is not generally feasible to match the impedance of the reflectometer with the wire. This means there will always be a reflection between the board and the wire being tested. The test-lead, connectors, adapters, etc. all add to this reflection in different ways. The physical connection to the wire is not always identical, and this difference gives an error of about 11 inches in our experience with 30 foot long wire. This is generally an absolute error, not percent error, as all error occurs at the front of the cable rather than being distributed along its length.

Another significant source of error in reflectometry methods that is quite important to testing of aircraft wires is the so-called "blind spot" for wires that are very short. This is caused by the reflected signal overlapping the incident signal, because the time delay is so small. This makes it difficult to identify the reflected signal. Two methods can be used to reduce this problem. One is to use a longer test lead to connect the reflectometer to the wire under test. This would effectively delay the reflected signal enough that the overlap can be reduced or avoided. This may be practical for handheld applications, but it is not practical for in situ applications, where the reflectometer is actually imbedded in the wiring system. Although there are no current in situ implementations, this is the goal of our research and is necessary in order to be able to locate faults on live wires in flight, so it is important to address this issue. This can be done using signal processing to identify the overlapping signals and extract the reflected response (Schmidt 2002, Pendayala 2004, Basava 2004).

With a basic understanding of reflectometry and the errors that are inherent in its use, the following sections describe several different types of reflectometry, each distinguished by the type of incident voltage used. Time domain reflectometry (TDR) uses a voltage step function. Frequency domain reflectometry (FDR) uses a set of stepped sine waves. Sequence time domain reflectometry (STDR) uses a pseudo noise (PN) sequence as the incident signal, and spread spectrum time domain reflectometry (SSTDR) uses a sine wave modulated PN code. Noise domain reflectometry (NDR) uses no signal at all, but rather only existing signal and its inherent noise on the wire. These methods will be compared for ease of use and interpretation, cost, size, ability to test live wires, and ability to analyze branched networks. The theoretical and practical accuracy are compared for each method.

A second class of sensors described in this paper are capacitance and/or inductance sensors. The capacitance of an open circuited cable and inductance of a short circuited cable are proportional to the length of the wire. Thus, if the capacitance (for open circuited wires) or inductance (for short circuited wires) can be measured, the length can be calculated. Several such methods have been tested (Chung, *et al.* IM-8025, Amarnath 2004), and found to be very accurate for single lengths of wires. These sensors tend to be the least expensive circuits available for testing wires, however they are not able to detect faults on wires that are live, and they cannot test wires that branch into multiple arms or networks.

2.1. Time domain reflectometry (TDR)

Time domain reflectometry (TDR) uses a short rise time voltage step as the incident voltage.

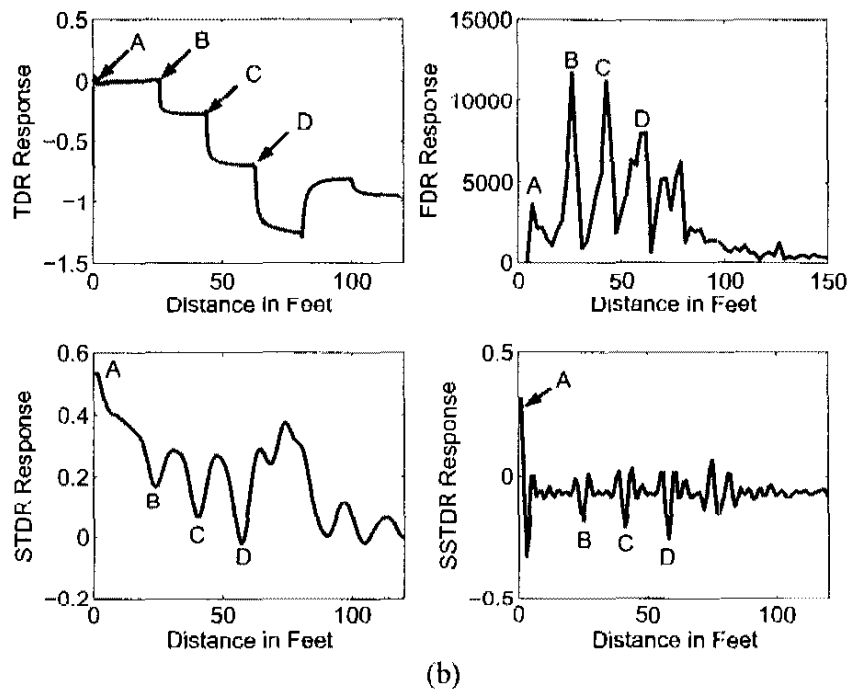
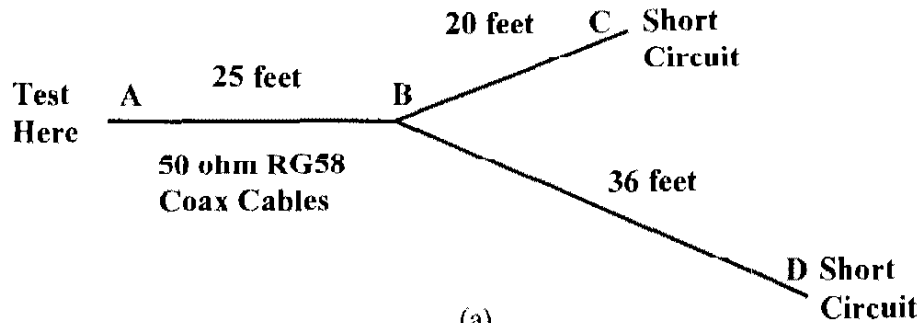

Fig. 3 (a) Network topology, (b) Reflectometry test signals of network shown (a) with TDR, FDR (MSR/SWR), STDR, SSTDR

(Waddoups 2002, Schmidt 2002, Jani 2003, Campbell Scientific). For simple loads such as wiring, the reflected voltages are also step functions. As described above, the length of the cable can be calculated from the time delay between the incident and reflected voltages and the velocity of propagation (V_p) of the cable. The magnitude and polarity of reflected voltage indicate the impedance (short, open, partial opens or shorts, etc.) at the discontinuity. The TDR response of a branched wire network is shown in Fig. 3, along with responses from other reflectometry methods. Steps in the response indicate reflections returned to the test point. The source of each reflection is marked on the figure.

The accuracy of TDR is controlled by the rise time of the pulse and the sampling rate of the receiver. The TDR100 from Campbell Scientific was used in our tests. The TDR100 generates a 14 microsecond pulse and samples the reflected wave at 12.2 pico-second intervals (Campbell Scientific). The expected accuracy is 0.24 cm, for a typical cable with 2/3 the velocity of light. One problem that limits that accuracy of the TDR is that the voltage step contains a very broad frequency and disperses (spreads out) as it goes down the cable. It is difficult to know where to “read” this voltage step.

Due to its large bandwidth, TDR has also been identified as a potential method for locating small anomalies such as frays or chafes if an extremely accurate initial baseline is available (Schmidt 2002, Jani 2003). There are both practical and theoretical reasons that obtaining a sufficiently accurate baseline to identify small anomalies is difficult or impossible. In practice, it would be very difficult (probably impossible) to obtain a baseline test of every wire that might go bad in a fleet of aircraft. The problem of maintaining this baseline was also discussed in the first part of this section. If the wire is moved, even a little, the small change in impedance and velocity of propagation can easily outweigh the even smaller reflection from the fray or chafe. This issue has been analyzed in detail (Griffiths, *et al.* 2005).

TDR requires a fast rise time pulse generator and fast sampler. It is therefore the most expensive (\$1000+) and generally largest of the methods described here. Benchtop-sized equipment is prevalent (DIT-MCO), and handheld TDR units are available also (3M™ Advanced Systems Tester 900AST, CM Technologies). At present, the smallest TDR that these authors is aware of is a PCMCIA card for a palm-sized computer (Arcade Electronics). Other groups are working on building TDR chips, which have the potential to be imbedded into the wiring system (Phoenix Aviation and Technology).

It is difficult to control the problem of “blind spots” with this method, except by adding a length of cable to the test lead. This method has limited application on wires that are live. If the wire is carrying a low frequency signal (400 Hz power, for instance), it is feasible to use TDR to test the wire while it is live. The TDR signal would need to be small enough to be below the noise margin of the aircraft signal. This creates a measurement problem for the TDR, as any noise (which may be as large as or larger than the TDR signal) will corrupt the TDR trace. TDR is therefore not optimal for testing wires that are live. TDR may be used for testing wires with multiple branches, such as the one shown in Fig. 3. The limitation of this (and all) reflectometry methods is that the junctions and ends of the branched network all result in reflections and multiple reflections that show up in the reflectometry trace, but it is difficult to extract the network topology from the reflectometry trace. This has led to the reputation that “it takes a PhD to read a TDR”, which frankly extends to all reflectometry methods. Automatic methods for extracting the topology are under development and have achieved initial success (Mahoney, *et al.*). Thus, TDR is as capable of testing branched networks but requires an automatic network topology extraction algorithm before this is practical.

2.2. Frequency domain reflectometry (FDR)

Frequency domain reflectometry (FDR) sends a set of stepped-frequency sine waves down the wire. There are three types of frequency domain reflectometry that are commonly used in radar applications that are distinct in that they each measure a different sine wave property (frequency, magnitude, and phase) in order to determine distance. Related methods are also found in wire testing. These are Frequency Modulated Continuous Wave (FMCW) systems (which measure frequency shift), Phase Detection Frequency Domain Reflectometry (PD-FDR) systems (which measure phase shift) (Furse, *et al.* 2003, Chung, *et al.* 2005, Tsai, *et al.* 2005), and Standing Wave Reflectometry (SWR) systems (which measure amplitude or nulls of the standing wave).

2.2.1. Frequency modulated carrier wave (FMCW)

FMCW systems vary the frequency of the sine wave very quickly, generally in a ramp function, and measure the frequency shift between incident and reflected signals, which can be converted to time delay knowing the speed at which the frequency is stepped. This has not been implemented for wire testing, because of limitations on speed at which the frequency can be swept and the accuracy at which

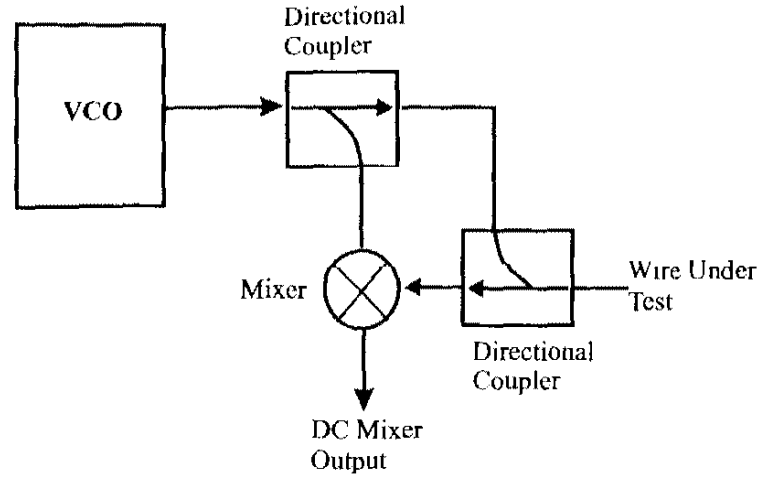

Fig. 4 PDFDR block diagram

the frequency shift can be measured (Furse and Kamdar 2002).

2.2.2. Phase detection frequency domain reflectometry (PD-FDR)

Phase Detection Frequency Domain reflectometry (PD-FDR), shown in Fig. 4 (Chung, *et al.* 2005), measures the phase shift between incident and reflected waves. (Furse, *et al.* 2003, Chung, *et al.* 2005) A voltage controlled oscillator (VCO) provides the sinusoidal signal that is stepped over a given bandwidth (f_1 through f_2) with a frequency step size Δf . A -10 dB sample of the incident sine wave is sent to the mixer, and the remainder is sent to the cable. The incident signal travels down the cable and reflects back from the load. The reflected wave is isolated from the incident wave by the second directional coupler and is sent to the mixer. The mixer “multiplies” the two sine waves, which gives signals at the sum and difference of their two frequencies. When they are at the same frequencies as they are in FDR, this difference is at zero frequency (DC). This DC voltage at the mixer output is the signal that the computer will detect and use to determine the length and load on the line. An analog-to-digital (A/D) converter used to read the mixer output effectively acts as a low-pass filter and removes the higher frequency components. The number of periods (‘frequency’) of the DC voltages collected over the injected frequency band is linearly dependent on the wire length. The Fast Fourier transform (FFT) of this collected waveform will give a Dirac delta function (single spike) at a location we will call *Peak*. The location of *Peak* in the FFT response is proportional to the length of the wire. The length is found from this peak index by (Chung, *et al.* 2005):

$$L = 2L_{\max} \left(\frac{Peak - Peak(0)}{N_{FFT} - 1} \right) = \frac{1}{2} \left(\frac{Peak - Peak(0)}{N_{FFT} - 1} \right) \left(\frac{N_F - 1}{f_2 - f_1} \right) v_p \quad (2)$$

where,

$Peak$ = location of the Dirac delta peak in the FFT (an integer value)

v_p = velocity of propagation in the cable (m/s)

f_1 = start frequency of the FDR (Hz)

f_2 = stop frequency of the FDR (Hz)

N_F = number of frequencies in the FDR = integer[$(f_2 - f_1) / \Delta f$]

Δf = frequency step size for FDR (Hz)

L_{max} = maximum length shown below

Peak = Peak index for corresponding length in FFT

N_{FFT} = number of points in the FFT (an integer value, generally 1024, 2048, 4096 or 8192)

To improve the resolution of the results, the measured data can be zero padded (Oppenheim 1975). The resolution (accuracy) of the measurements (ΔL) is given by Furse, *et al.* (2003), Chung, *et al.* (2005):

$$\Delta L = v_p / (2 N_{FFT} \Delta f) \tag{3}$$

The maximum length (L_{max}) that can be measured on an ideal wire is limited by the frequency step size and the Nyquist criterion:

$$L_{max} = \frac{v_p}{4\Delta f} \tag{4}$$

A sample set of responses of different lengths of a shielded twisted pair M27500-24SE2S23 wire is shown in Fig. 5(a), and their FFTs are shown in Fig. 5(b). The peak location in the FFT is substituted

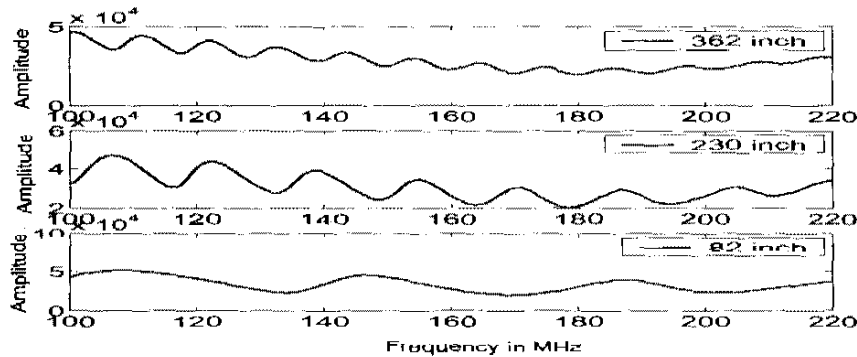

(a)

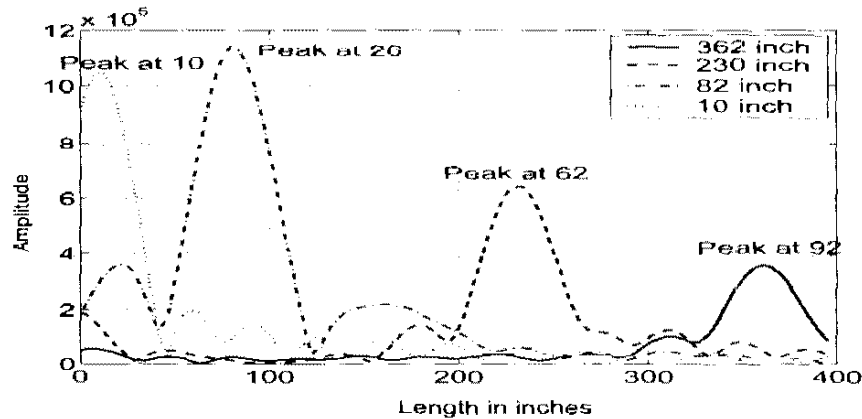

(b)

Fig. 5 PD-FDR results for open circuited RG58 50ohm coax. (a) DC output of the mixer as a function of stepped frequency, and (b) the Fourier transform of the results in (a) with $N_{FFT} = 2048$. The reduction in height is caused by the attenuation on the wire. From Furse, *et al.* (2003)

into Eq. (2) to find the wire length. The velocity of propagation ($0.66c$) is shown in Table 1 for this wire (Furse, *et al.* 2003, Chung, *et al.* 2005).

FDR systems are relatively inexpensive compared to TDR, as the electronics are simpler. PD-FDR requires a voltage controlled oscillator (VCO), two directional couplers, a mixer, and associated control circuitry. These components could be integrated into a single chip, so it is feasible to integrate this system directly into the wiring system. Such in situ systems are currently under development (Chung 2003).

Automatic analysis is quite easy with FDR methods, so they are relatively easy to use. Unlike TDR, very little frequency dispersion is seen in this method, as it is not as broad band as TDR, and the peak locations are clearly visible. PD-FDR is also capable of measuring branched networks of wires, where a peak in the FFT would be observed for each reflection and multiple reflections in the network, such as the response shown in Fig. 3. The same limitation that this does not directly provide the network topology exists as for TDR. FDR methods can be used on live wires, provided that the test frequency is not within the frequency range of the existing signal on the wire, and that the FDR is below the noise margin of the signal. It is not optimal for live wires, however, as noise from the existing signal can provide significant corruption of the FDR response that may or may not be effectively filtered by the FFT. PD-FDR has been demonstrated for wires 4 inches to 360 inches in length (Chung, *et al.* IM-8025). Analysis of wires less than 3 feet requires special treatment to remove the low frequency associated with the short connection between the PD-FDR board and the cable under test (Schmidt 2002, Furse, *et al.* 2003, Chung, *et al.* 2005, Chung, *et al.* IM-8025, Basava 2004). This is similar to the blind spot in TDR.

2.2.3. Standing wave ratio (SWR)

Standing wave ratio (SWR) systems measure the magnitude of the standing wave created by the superposition of the incident and reflected signals on the wire. The sum of these two sine waves will have a series of peaks that are caused by their constructive interference and nulls caused by destructive interference. As the frequency is swept, these nulls can be identified (as described in section 3a), or the pattern of the standing wave is proportional to the response obtained from the PDFDR (as described in section 3b). The frequency must be swept through multiple nulls, because otherwise wires that are multiples of a wavelength are indistinguishable. The two types of SWR are described below (Eclipse Co.).

2.2.3.1. Null detection

For null detection SWR, the frequency is stepped until a null in the standing wave is observed, and from this, the distance to fault is found (Oppenheim 1975). SWR has accuracy similar to the PD-FDR described above for hard faults (open and shorts) where the incident and reflected signals are approximately the same magnitude (the reflected wave will be somewhat less, depending on the attenuation on the line, but for frequencies in the kHz range where the SWR is currently implemented, this is negligible for most types of aircraft cable). When the fault is not an open or short, however, the magnitude of the reflected wave is reduced and overshadowed by the incident wave, which makes the nulls in the standing wave less pronounced and therefore less accurate to measure. This effectively limits the SWR to hard faults. SWR also cannot be used for branched networks, as the standing wave is made up of the incident plus several reflected waves, thus making it more complex. If the magnitude of the wave was measured at every frequency, the multiple reflections could, in theory, be extracted. This is what the Mixed Signal Reflectometry system described next does.

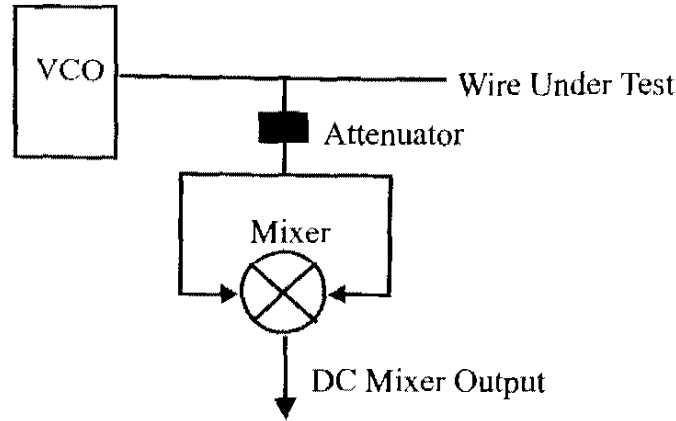

Fig. 6 MSR circuit diagram

SWR devices are relatively small and inexpensive, requiring only a sine wave generator (generally a voltage controlled oscillator), a received signal strength indicator (RSSI) chip, and some basic control circuitry. These devices could be integrated into a single chip, and would be feasible to integrate within the wiring system itself. This type of SWR system has been implemented in handheld wire testing systems (Eclipse Co.).

2.2.3.2. Magnitude detection -- mixed signal reflectometry (MSR)

A Mixed Signal Reflectometer (MSR), shown in Fig. 6, is like a PD-FDR without the directional couplers (thus saving sizeable expensive) or an SWR that measures the squared magnitude of the standing wave for all frequencies (thus improving accuracy, especially for smaller reflections). Like the PDFDR, a voltage controlled oscillator (VCO) provides a sinusoidal signal that is stepped over a given bandwidth (f_1 through f_2) with a frequency step size Δf . It reflects back and is superimposed on the incident wave. The combination of the incident and reflected waves (standing wave) goes through the attenuator, which reduces the amplitude of the signal to prevent overloading the mixer. The attenuated signal feeds into both inputs of the mixer. The output of the mixer is the square of the sum of the incident and reflected signals (Tsai, *et al.* 2005):

$$\begin{aligned} & \{ B[\sin(\omega t) + \alpha\sin(\omega t + D)] \}^2 \\ & = B^2 \left\{ \left[\frac{1}{2}(1 + \alpha^2) + \alpha\cos(D) \right] + \left[\frac{1}{2}\sin(2\omega t) + \alpha\cos(2\omega t + D) + \frac{1}{2}\sin(2\omega t + 2D) \right] \right\} \quad (5) \end{aligned}$$

where

α : attenuation

τ : signal delay from the wire

ω : frequency of VCO output,

A : amplitude of the VCO output

B : amplitude of the sinusoidal wave after reflection and attenuation.

This contains the first harmonic of the sine wave and a DC value,

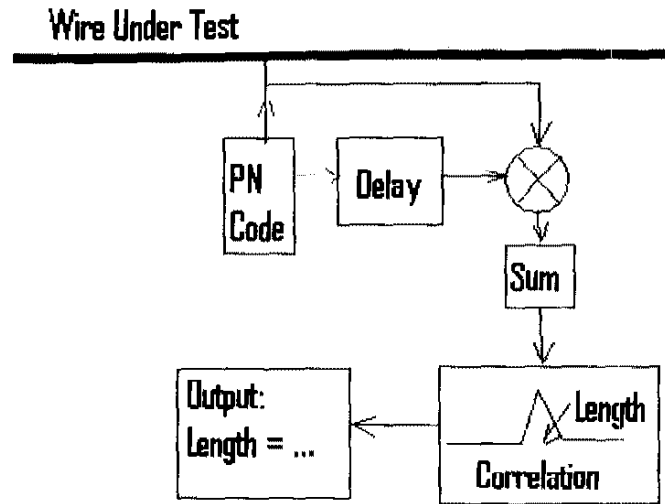

Fig. 7 Sequence (STDR) Test System. For SSTDR, the input signal is a sine wave modulated PN code

$$B^2 \left[\frac{1}{2} (1 + \alpha^2) + \alpha \cos(D) \right] \quad (6)$$

This DC value is the same as for the PD-FDR, such as shown in Fig. 5. The mixer output goes into a digital to analog converter, which automatically filters out the high frequency component. The DC values as a function of frequency are a sinusoidal wave whose frequency is linearly proportional to the wire length, virtually identical to the FDR responses shown in Fig. 5. The MSR is more accurate than the SWR for small reflections, however this advantage has not been found to have practical application, as it still cannot analyze the very small anomalies associated with frays or chafes. MSR is less expensive and smaller than PD-FDR, since it does not require the directional couplers. For branched networks, the MSR response includes the multiple reflections plus their sums and differences, which makes its response more complex to calculate than the PD-FDR branched network response. Limitations on the use of MSR for live wires and short length wires are virtually identical to those for PD-FDR.

The MSR system is less expensive than either the PD-FDR or SWR. It requires only a voltage controlled oscillator (VCO), mixer, and related control circuitry. It is feasible to integrate this system into a single chip and imbed it directly into the wiring system.

2.4. STDR/SSTDR

Block diagrams of Sequence Time Domain Reflectometry (STDR) (Furse, Smith, Safavi and Lo 2005) and Spread Spectrum Time Domain Reflectometry (SSTDR) are shown in Fig. 7 (Furse, *et al.* 2005, Smith 2003). STDR uses a pseudo noise (PN) code as the test signal, as shown in Fig. 8a (Furse, *et al.* 2005, Smith 2003). The PN signal can be very, very small compared with the aircraft signal on the wire (–20 dB down, for instance) and is well below the allowable noise floor of the aircraft signal shown in Figs. 8a and 8b (Furse, *et al.* 2005, Smith 2003). Although the PN code magnitude is small, it is relatively long (1023 bits, for example) and has a distinct and recognizable pattern. The correlation responses of STDR and SSTDR are shown in Figs. 8(c) and 8(d) (Furse, *et al.* 2005, Smith 2003). The

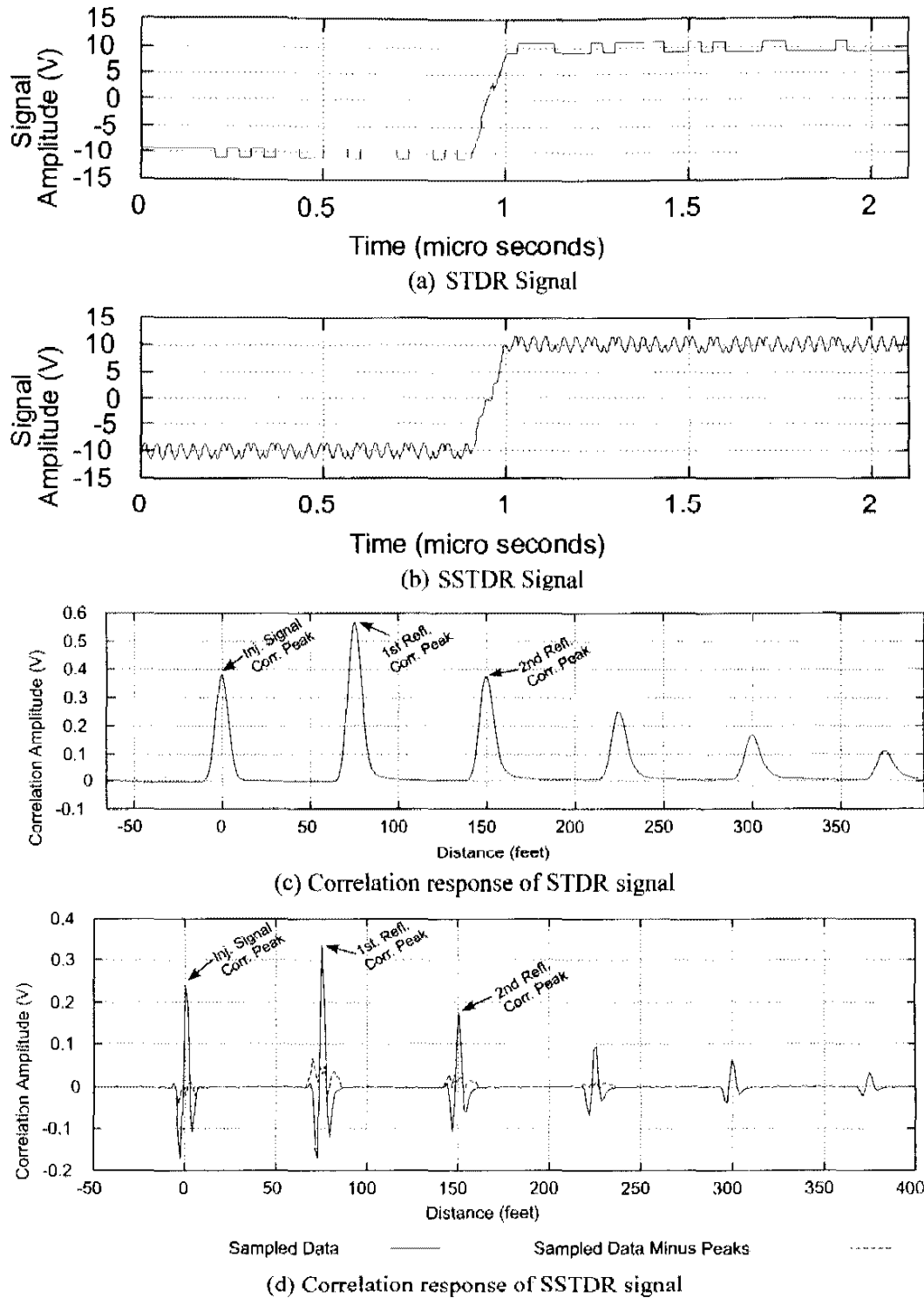

Fig. 8 STD and SSTDR signal added to a 10 V RMS signal at 30 MHz. The S/SSTD signals are a Maximum Length (ML) Code 1V RMS at 58 MHz, with a 58 MHz sine wave modulation in the case of SSTDR. The magnitude of the S/SSTD signals can be much smaller than shown here, depending on the signal on the wire. (a) STD Signal (b) SSTDR Signal (c) Correlation response of STD signal (d) Correlation response of SSTDR for a 75 foot wire (RG58 coax) that is open circuited on the end. From Furse, *et al.* (2005), Smith (2003).

signal at the source end (a combination of incident and reflected waves) is correlated with a test copy of the PN code. Correlation delays, multiplies, and sums the signal with the test PN code. When the codes are synchronized, a high value is obtained, and when the codes are not synchronized, a low value is obtained. The correlation enables STDR to run on live wires far better than any of the other reflectometry methods described so far. The length of the wire (distance to fault) is easily determined from the correlation data, as shown in Fig. 3.

A slight change to the STDR signal gives even better performance for live wires. Spread Spectrum Time Domain Reflectometry (SSTDR) uses a sine wave modulated PN code as the test signal, as shown in Fig. 8b. The correlation peak obtained is sharper than the STDR peak. This method is very efficient and accurate for live wire testing, and has been shown to be accurate with the existing data signal 50 dB greater than the SSTDR signal. This is because the spectrum of the SSTDR signal is outside of the spectrum of the data signal (Smith 2003).

Height of the peaks used to determine the wire length for the S/SSTDR system relative to the noise floor depends on the speed, length, type, and integration time of the PN code (Arcade Electronics). The system shown here uses a PN code of length 127 with a frequency of 58 MHz. The accuracy of the S/SSTDR system is controlled by the distance between subsequent samples of the correlation peaks, which is controlled by the precision of the shifter in the correlation step. A time shift of T gives a distance error of $\Delta L = (\text{velocity of propagation})(T/2)$. If only individual chips are correlated (as opposed to "subchips"), the accuracy is insufficient for this application). For our system, subchip sampling at a rate of 10 samples per chip is required to obtain a resolution of 17 cm. This error can be substantially reduced (to about 3 cm) by fitting a curve to the correlation peaks to more precisely locate peaks that are missed by sparse correlation sampling (Pendayala 2004).

The S/SSTDR system has several advantages over other types of reflectometry systems. First, since it can run very well on live wires, it can create and store its own dynamic baseline. Baselineing is done to determine when something in the wiring system has changed. A baseline shows when the wire is "good", and the difference from the baseline shows where the fault has occurred. Baselineing is a serious limitation of reflectometry systems today. Even if a baseline could be taken for every wire in a plane, the vibration and normal changes within a plane would corrupt this baseline so much that it would not be very useful later when a fault occurred, as discussed in the TDR section. The SSTDR system eliminates this problem and locates changes within a wiring system, using a dynamic baseline that it creates itself. There is still one unresolved issue about S/SSTDR baselineing. Loads with time-varying impedance (such as equipment being turned on and off) will show up as changes to the baseline, and these changes need to be distinguished from real faults. It would be relatively simple to ignore all changes at the location of the load, however this would mean that a fault at the connection point to the load would be missed. Additional information would be needed to make this distinction, such as an additional sensor placed at the load, connection to the control system for the load indicating when changes were expected (and could therefore be ignored), or distinction between the fault and load change signatures (similar to an arc fault circuit breaker).

Perhaps the most significant advantage of the SSTDR system is that since it is testing while the wires are live, the small "arc faults" or other intermittent faults are actually open or short circuits ("hard faults") for a short duration of time. After their intermittent event, the fault is often a "soft fault" with an impedance discontinuity that is too small to locate. The important aspect of intermittent fault location is to test the wire while the fault occurs, and the SSTDR system is the only method that we know of that can test the wire while it is live without interfering with it (Furse, Smith, Safavi and Lo 2005).

The S/SSTDR is capable of being miniaturized into a mixed signal IC, which will make it very small and likely the least expensive reflectometry system available. It is very feasible to consider imbedding this system in the wiring system. S/SSTDR is capable of analyzing branched networks, with the same limitations as FDR and TDR, that the network topology must be extracted from the multiple peaks in the reflection data.

3. Capacitance and inductance sensors

The reflectometry methods described in the previous section are all based on measuring the reflection from an impedance discontinuity. This section describes a different method for measuring wire length based on the bulk capacitance of an open circuited wire or the inductance of a short circuited wire. Capacitance sensors are generally about as accurate as reflectometry methods, but inductance sensors are more sensitive to the highly variable metallic structure around the wire and are therefore slightly less accurate. Both methods are less expensive than reflectometry methods and can be shrunk to be very small. They are not usable for wires that are live, and, since they measure the bulk capacitance or inductance, they cannot distinguish between different arms of a branched network and therefore are only useful on unbranched wires.

The capacitance value 'C' of any two conductors is based on the distance (d) between the conductors, the area of the conductor (S), and the permittivity ϵ ($\epsilon = \epsilon_r \epsilon_0$, $\epsilon_0 = 8.854 \times 10^{-12}$ F/m) of the dielectric separating the conductors. ϵ_r is the relative permittivity to the permittivity of air ϵ_0 . Eq. (7) shows the capacitance value of two parallel plates. For two circular parallel conductors (round wires), for instance, the capacitance and inductance are given by Eqs. (7-10) (Chung, Amarnath, Furse, Green 1999, Wadell 1991, Hayt 1989):

$$C = \frac{\pi \epsilon}{\cosh^{-1}\left(\frac{D}{d}\right)} \text{ (Farads/m)} \quad (7)$$

$$L = \frac{\mu}{\pi} \cosh^{-1}(D/d) \text{ (Henries/m)} \quad (8)$$

where d is the diameter of the conductors, D is the distance between their centers, ϵ is the permittivity of the insulation between them, and μ is the magnetic permeability of the insulation ($\mu = \mu_r \mu_0$, $\mu_0 = 4\pi \times 10^{-7}$ H/m). Eqs. (7-8) are appropriate for use for typical loosely bundled and tied aircraft wire, however it is well known that these values will have some variation due to variation in the distance between two wires used as a pair and other wires that come between them. Twisted pair wire has approximately 20% greater capacitance than simple parallel wire due to extra length from the twists (Wadell 1991).

Table 1 gives the capacitance and inductance per meter for several types of aircraft wire that are open and short circuited. The bulk capacitance of an open circuited wire and the bulk inductance of a short circuited wire are then linearly proportional to the wire length (Chung, *et al.* IM-8025). Thus, measuring the bulk capacitance or inductance and knowing the wire type can be used to determine the wire length and if it is open or short circuited. There are a number of ways of measuring the bulk capacitance and inductance including voltage dividers, oscillator circuits, and other impedance measurement methods

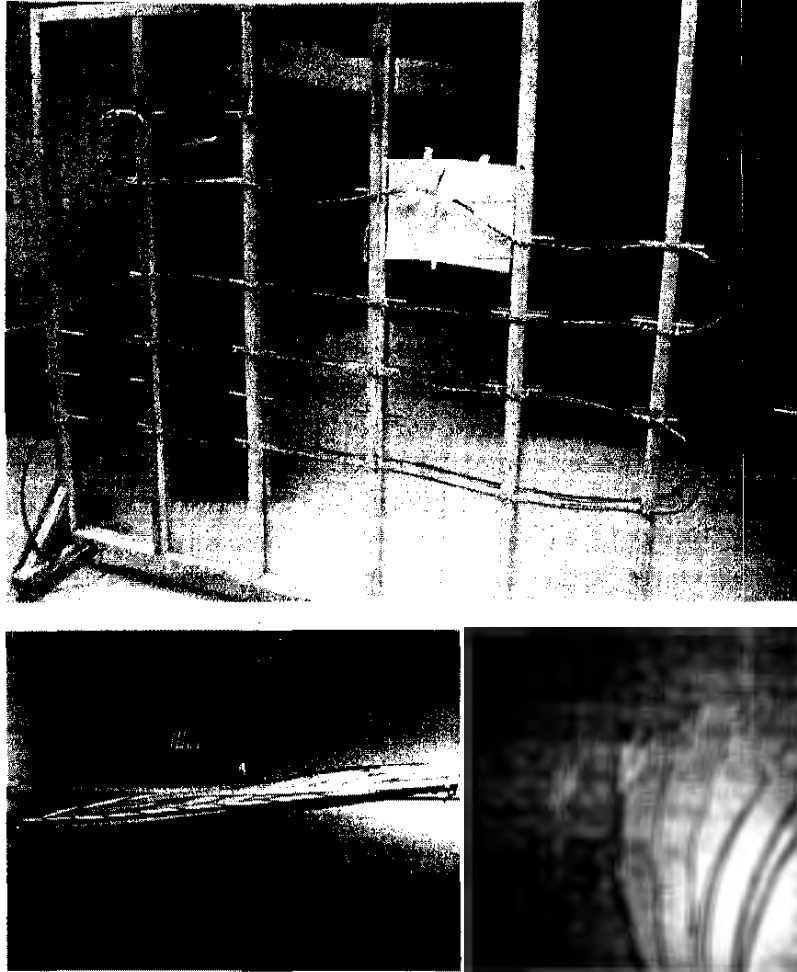

Fig. 9 Test bed, wire bundles and wire types

(Chung, *et al.* IM-8025). These methods basically use the wire as an inductor or capacitor in a circuit and produce a voltage, current, or frequency shift depending on the L or C values.

As with reflectometry, there are some potential sources of error in capacitance measurements that should be considered. From Table 1, it is clear that the variation in capacitance or inductance per unit length between wires is significant enough that the wire type must be known. Another issue is the variation of capacitance and inductance between similar wires in a loosely tied bundle of wires (often 20-150 wires), where the wires may not stay uniformly spaced. This error was found to be less than 2% for a bundle of 20 M22759/16-22-90 wires 392 inches long. Variations of about 4 pF out of 350 pF (for open circuited wires) and 0.01 μ H out of 9.20 μ H (for short circuited wires) were measured (Chung, *et al.* IM-8025).

3.1. Results and comparison

The test bed that was used to measure the relative accuracy of each method is shown in Fig. 9. It also shows the bundle of wire and wire types. There are twisted wires, coax, and individual wires combined into a single bundle, described in detail in Table 1. They are bundled and tied next to the ground plane

Table 2 Comparison of reflectometry methods

Wire fault sensor	Cost (\$/one)	Accuracy (inches)	Minimum measurable length (inches)	Estimated* maximum length (feet)	Computational requirement**	Possibility of network topology recognition
TDR (Campbell Scientific)	\$1000+	6 -12	5	100 +	Edge Identification	Yes
PD-FDR (Furse, <i>et al.</i> 2003 Chung, <i>et al.</i> 2005)	\$20	2	4	50 +	FFT, Peak Identification	Yes
MSR (Tsai, <i>et al.</i> 2005)	\$10	2	4	50 +	FFT, Peak Identification	Yes
STDR/SSTDR (Furse, <i>et al.</i> 2005, Smith 2003)	\$200 (\$20 chip)	1	4	70 +	Peak Identification	Yes
Capacitance Sensor (555 Timer) (Chung, <i>et al.</i> IM-8025)	< \$1	1	1	100 +	Linear Curve Fit	No
Inductance Sensor (Colpitts Oscillator) SWR no results (Eclipse, Co., Medelius and Simson 1999)	< \$1	1	1	100 +	Linear Curve Fit	No

*Maximum length is based on maximum length we have physically measured (typically 100 feet) and observed attenuation. The maximum length is dependent on wire type. Lossy wires have more attenuation and less measurable length than very low loss wires.

**FFT requires significant computational power. Peak and edge identification can be very minimal or can be more extensive if signal processing is used to improve results. Linear curve fit requires minimal computational power.

to mimic the aluminum aircraft body. The bundled wires were available in lengths of 25, 50, 300 and 500 inches that were connected together to measure total wire lengths about 800 inches. The connectors used were simple pin and socket connections, without the potted connector they are normally placed in. Less than 2% reflection was observed at each connection point, so these connections were assumed to have minimal effect on the results.

Each test method was connected to a pair of wires on the test board. For twisted wires one of the wires was connected to the "hot" lead of the test system and the other to ground. For single wires, a second single wire in the bundle was used as the ground. For coax, the inner and outer conductors were used individually. These test systems were therefore always using a second wire running exactly parallel with the first as the ground return path for the current. Tests using the metallic aircraft "skin" have proven to be less accurate, particularly when the wire does not stay the same distance from the aircraft body, however they may still be useable. Additional testing is needed to determine if it is even feasible to use the skin as the return path for ground when only a single wire is available in a run. Fortunately, the vast majority of wires are bundled or have a pair, so the tests that we do reflect the vast majority of aircraft wiring. Wires were left open circuited on the ends. Other tests with the wires shorted together or to the metal ground plane showed that open and short circuits have virtually identical accuracy for all methods.

The accuracy of each method shown in Table 2 was determined by comparing the measured results at each of the lengths with the known physical length. The worst error for any length and any wire type is given as the accuracy of each method. Some wire types are known to be worse than others. For instance, shielded wires are better than unshielded, and twisted wires are better than loosely bundled

wires. The worst error is usually detected on the longest wire with more connections and resultant impedance discontinuities.

4. Conclusions

This paper compares several types of reflectometry systems and capacitance and inductance sensors. The capacitance and inductance methods are the simplest, smallest, and least expensive sensors. Their range is large, and they do not have limitations on minimum measurable length. Their accuracy is comparable to or sometimes even better than the reflectometry methods. Their only significant limitations are that they cannot be used on live wires, and they are not capable of locating faults on branched wiring networks, even with more advanced computer processing of the data.

Frequency domain reflectometry methods are only slightly larger, more expensive, and more complex than capacitance and inductance sensors, and some can be used on branched wire networks. It is important to note that the exact minimum and maximum length and the expected accuracy are dependent on the specific settings and engineering designs of each sensor. For example, increasing the bandwidth of the FDR methods or decreasing the rise time of the TDR (which is equivalent to increasing its bandwidth) improves the accuracy. Increasing the length of time between rise and fall of the TDR pulse or increasing the number of frequency samples of the FDR methods increases the maximum range. The minimum length is limited by the ability of the system to resolve two overlapping reflections. For TDR, decreasing the rise time of the pulse and the sampling interval helps here. For FDR, removing the expected incident pulse using signal processing and increasing the resolution of the Fourier transform used to analyze the FDR data reduce the minimum measurable length. For all of the reflectometry systems, it is possible to tell that there is a reflection within the minimum length, which is generally on the order of 2 feet, but not to determine accurately within this distance where the fault occurs. In practice, this is probably not a severe limitation for aircraft or home wiring, as knowing where the fault has occurred to within 1 or 2 feet is sufficient. The accuracy of these methods are all comparable and are generally sufficient for both aircraft and home applications.

An important aspect of the reflectometry systems is the ability to run on live systems to detect intermittent faults. Currently, technicians would like to locate the insulation chafes and frays that allow intermittent faults. That is not possible with either reflectometry or capacitance/inductance measurements, however locating the intermittent faults that are related to these conditions can be done instead. SSTDR reflectometry systems provide the best signal to noise ratio of all of these reflectometry systems and can therefore be used on low frequency (60 or 400 Hz, for instance) circuits as well as those carrying high speed data signals such as Ethernet or Mil Std 1553. The next best signal to noise ratio is give by the STDR system, which is ideal for low frequency circuits, or even those into the kHz region. The STDR has less loss on the cable than SSTDR and is therefore able to test longer cables. Frequency domain reflectometry systems are limited to low frequency circuits, as they would interfere with the higher frequency lines. Even for the low frequency circuits, their signal to noise ratio is not as good as the STDR. The same holds true for TDR. S/SSTDR systems are therefore the best for locating intermittent faults or for real time testing of live circuits.

Another important aspect of reflectometry systems for which solutions are just beginning to emerge is analysis of branched networks, since many of the power distribution systems that are of prime importance to test are extensively branched. The capacitance and inductance sensors are not capable of measuring branched networks, so the system would need to be disconnected at each junction in order to

use this test system. This defeats the purpose of having a single end test system. All of the reflectometry systems have the potential to locate faults on branched networks, since individual peaks or steps will be seen in their response for each reflection point. Reflectometry responses from branched networks are often too complex to interpret by hand. The SWR and MSR systems have the most difficult (and in some cases impossible) responses to evaluate, as they give peaks not only at the junctions, ends of wires, and multiple reflection points, but they also provide all of the sums and differences of each of these points. TDR, S/SSTDR, and PD-FDR are all similar in their responses and capability in this regard. Overlapping peaks/steps from reflections occurring very near the branches and multiple reflections that coincide with reflections at ends or junctions of branches are challenges for this method that can be addressed with a variety of signal processing techniques. Some aspects of networks will always be impossible to resolve with a single point measurement. For instance, when one of two identical arms breaks, it will be possible to tell how far away the break is, but it will not be possible to tell which arm is broken. When an open and short circuit occur at the same distance from the test system, the reflections cancel each other out and appear completely invisible. In cases such as these, multiple test points on the same system will be needed, which will in turn require the coordination and communication of data for analysis.

Smart imbedded test systems for wiring hold the promise of revolutionizing the way large wiring systems are designed and maintained. The ability to precisely identify and locate wiring faults remotely enables monitoring, diagnosis, control, and potentially even prognosis of degrading systems. Critical elements including sensors that are small enough to be imbedded, that are capable of locating faults on live systems, and that can be used on branched networks are all rapidly emerging and are showing excellent results.

Challenges for a fully imbedded wiring test system still remain. Not all network analysis can be completed from a single test point, which means that multiple sensors need to communicate and work together. The complexity of today's wiring systems means that there could be potentially thousands of distributed sensors in the highly lossy, highly multipath communication environment of a building or plane. Communication can be efficiently done on the wires being tested, in some cases potentially with the same sensors that are used to test the wires, but if the wire breaks, then critical information would be lost. Not all arms of a wiring system are connected (for instance, data and power lines). A wireless communication system is needed. Today's communication protocols are optimized for high bandwidth data, but the data from these sensors (like most other sensors) is very small, and the overhead from the communication protocol dominates the transmission. Thus, new protocols for large numbers of sensors sending small quantities of data are needed. This normally requires an understanding of the communication channel, which is not available for within vehicles.

Another challenge for wiring systems is being able to handle the multiple wires within a bundle, either with multiplexers or with discrete (but very small and inexpensive) sensors for each wire. S/SSTDR is capable of simultaneously testing each wire without causing electromagnetic interference with the other wires, but other reflectometry systems could receive false reflections from wires other than the one they are testing. Multiplexers are available for high frequency signals, and can be miniaturized, although there are issues of isolation and single points for failure within the system.

Another significant consideration is what to do with all of the data that is processed from a large network of sensors. Methods to integrate the location of faults that is given in meters with the wiring database that shows the location and routing of wires is very important. Eventually, it would be ideal to have a system that shows the maintainer graphically where the fault occurred and how to fix it, much like a copy machine does when clearing a paper jam.

The test methods that are described in this paper can be used for more than just locating faults on wiring systems. "Sacrificial" wires can be imbedded in concrete or other material, so that the wire breaks when damage occurs to the structure. The location of damage could be inferred by measuring the wire. Corrosion may also be detectable in this way. Many of the methods described here have parallels in fiber optics, which opens up a whole new opportunity both for testing of fiber optic systems and for sacrificial optical fibers.

Aging wiring has plagued us for decades, and the proliferation of electronic systems within our society is further propagating that problem. Test methods to locate faults, or to locate early intermittent predecessors to catastrophic faults, can dramatically decrease the maintenance cost and time burdens as well as improve safety. Handheld systems are rapidly emerging, and systems that can be used on live wires are following close behind. These new methods promise a dramatic shift in electrical maintenance and open up opportunities for robust and inexpensive imbedded structural sensors that have not previously existing.

Acknowledgements

This work was supported in part by the National Science Foundation (grants 6139144 and 0330465), NAVAIR (on subcontracts through Management Sciences, Inc.), the US AFRL (on subcontracts through AT&T Government Solutions), and the Utah Centers of Excellence program.

The following students contributed to the development of the technologies that were compared in this paper: Nilesh Kamdar, Rakesh Dangol, Arvind Jakayar, Brent Waddoups, Mark Schmidt, Derek Bates, Krishna Konda, Grandhi Nagendra Prasad, Jeremy Pruitt, Santi Bhushana Reddy Basava, Deekshit Dosibhatla, Dr. Paul Smith, Alok Jani, Anit Kuruvilla, Ryan Hanks, Ravi Gopal, Alyssa Magelby, Anitha Jayasingh, Nirmal Nath Amarnath, Praveen Pendayala, Vasudev Srinivasan, Nilay Jani, Clark Landeen, Eric Cannon, Suketu Naik, Chris Griffin, Rory Buchanan, John Mahoney, Jill Anderson, Brittany Baker, Sydney Chamberlain, Danny Repko, Korey Curtis, Greg Hill, Pei Jung Tsai, Michael Lawrence, Zach McKean, Richard Morrill, Arthur Mahoney.

References

- Amarnath, Nirmal Nath, "Capacitance and inductance sensors for the location of faults in wires", MS Thesis, University of Utah, 2004.
- Arcade Electronics, Psiber CT50 CableTool Multifunction Cable Meter, http://www.arcade-electronics.com/psiber/psiber_ct50_cabletool.html.
- Basava, Santi B. (2004), "Detection and location of cable faults using reflectometry methods", MS Thesis, Utah State University.
- Campbell Scientific, "TDR100 Instruction Manual", [<ftp://ftp.campbellsci.com/pub/outgoing/manuals/tdr100.pdf>].
- Chen, C. S., Rocmer, L. E. and Grumbach, R. S. (1978), "Cable diagnostics for power cables", *IEEE Annual Conference of Electrical Eng. Problems in Rubber and Plastic Industries*, 20-22, Apr.
- Chung, You Chung and etc. (2003), "Non-destructive fault location on aging aircraft wiring networks Part 1—Cost-optimized solutions", *IEEE AP-S and USNC/URSI National Radio Science Digest*, Columbus, Ohio.
- Chung, You Chung, Amarnath, Nirmal and Furse, Cynthia, "Capacitance and inductance sensors for open and short ends circuit wire faults detection", *IEEE Trans. Instrument and Measurements*, IM-8025, in review.
- Chung, You Chung, Furse, Cynthia, Pruitt, Jeremy, (2005) "Application of phase detection frequency domain

- reflectometry for locating faults in an F-18 flight control harness”, *IEEE Trans. Electromagnetic Compatibility*, **47**(2), 327-334.
- CM Technologies, <http://www.ecadusa.com/prod01.htm>.
- Conley, Tim (2003), “The relationship among component age, usage (reliability) and cost of naval aviation repairables”, *Aging Aircraft Conference 2003*, New Orleans, Sep.
- DIT-MCO Model 2115-Benchtop. <http://www.ditmco.com/wiring.asp?id=2>.
- Eclipse Co. SWR meter, <http://www.eclipse.org/Home.htm>.
- Furse, C. and Kamdar, N. (2002), “An inexpensive distance measuring system for navigation of robotic vehicle”, *Microwave and Optical Tech. Letters*, **33**(2), 84-97, April.
- Furse, C., Haupt, R. (2001), “Down to the wire: The hidden hazard of aging aircraft wiring”, *IEEE Spectrum*, 35-39, Feb.
- Furse, C., Smith, P., Safavi, M. and Lo, C. (2005), “Feasibility of spread spectrum sensors for location of Arcs on live wires”, *IEEE Sensors J.*, **5**(6), 1445-1450.
- Furse, Cynthia, Chung, You Chung, Dangol, Rakesh, Nielsen, Marc, Mabey, Glen, Woodward, Raymond, (2003), “Frequency domain reflectometry for on board testing of aging aircraft wiring”, *IEEE Trans. Electromagnetic Compatibility*, 306-315, May.
- Furse, Cynthia, Lo, Chet, Chung, You Chung, Pendayala, Praveen and Nagoti, Kedarnath (2005), “Spread spectrum sensors for critical fault location on live wire networks”, *J. Struct. Control Health Monitoring*, **12**(3/4), 257-267.
- Green, E. (1999), “A simplified derivation of the capacitance of a two-wire transmission line”, *IEEE Transactions on Microwave Theory and Techniques*, **47**(3), 365-366, Mar.
- Hayt, W. H. (1989), *Engineering Electromagnetics*, 5th edition, McGraw-Hill Book Co.
- Iskander, M. F., *Electromagnetic Fields and Waves.*, Englewood Cliffs, NJ: Prentice Hall, 1992.
- Jani, Alok (2003), “Location of small frays using TDR,” MS Thesis, Utah State University, Logan, Utah, 2003.
- Griffiths, Lance, Parakh, Rohit, Furse, Cynthia and Baker, Brittany (2005), “The Invisible Fray: A critical analysis of the use of reflectometry for Fray location”, Accepted to *IEEE J. of Sensors*.
- Lloyd, Robin (1999a), “64 cases of wiring problems found on shuttle fleet”, *CNN Reports* Sep. 3, <http://www.cnn.com/TECH/space/9909/03/shuttle.repairs/>.
- Lloyd, Robin (1999b), “NASA delays shuttle launch to inspect wiring”, *CNN Reports* Aug. 13, <http://www.cnn.com/TECH/space/9908/13/shuttle.update/>.
- Mackay, N. A. and Penstone, S. R. (1974), “High-sensitivity narrow-band time-domain reflectometer”, *IEEE Trans. Instrumentation and Measurement*, **23**(2), 155-158, June.
- Mahoney, Arthur, Lo, Chet, Chung, You Chung, and Furse, Cynthia, “Use of genetic algorithms and reflectometry for identification of network topologies”, *IEEE Trans Electromagnetic Compatibility*.
- Medelius, P. J., Simson, H. J. (1999), “Non-intrusive impedance-based cable tester”, US Patent 5977773, Nov.
- NASA (2000), Wiring Integrity Research (WIRE) Pilot Study A0SP-001-XB1, August.
- NSTC (2000), “Review of federal programs for wire system safety”, *White House Report*, Nov.
- Oppenheim, A. V. (1975), *Digital Signal Processing*, Prentice-Hall, Englewood Cliffs, N.J.
- Pendayala, Praveen K. (2004), “Development of algorithms for accurate wire fault location using spread spectrum reflectometry”, MS Thesis, University of Utah.
- Phoenix Aviation & Technology, <http://tooling.tycoelectronics.com/pdf/Embedded.pdf>.
- Schmidt, Mark (2002), “Use of TDR for cable testing”, MS Thesis, Utah State University, Logan, Utah.
- Smith, Paul (2003), “Spread spectrum time domain reflectometry”. Ph.D. dissertation, Utah State University.
- Tsai, P., Lo, C., Chung, Y. C. and Furse, C. M. (2005), “Mixed signal reflectometer for location of faults on aging wiring”, *IEEE Sensor Journal*, **5**(6), 1479-1482.
- Waddoups, Brent (2001), “Analysis of reflectometry for detection of chafed aircraft wiring insulation”, MS Thesis, Utah State University, Logan, Utah, (all theses and dissertations in this paper can be obtained from: www.lib.umi.com).
- Wadell, B. (1991), *Transmission Line Design Handbook*, Artech House, Norwood, MA.

White, Eddie (2004), Personal Communication, 4/13/2004.

3M™ Advanced Systems Tester 900AST http://products3.3m.com/catalog/us/en001/government/gsa/node_G4Q48DLDN3be/root_GS3RBW6QFVgv/vroot_GSL4YG63GRge/gvel_W4S153Z2F4gl/theme_us_gsa_3_0/command_AbcPageHandler/output_html.

CC